

# The wave energy converter *Wave Star*

*A multi point absorber system*

Morten Kramer, Aalborg University (AAU), Denmark

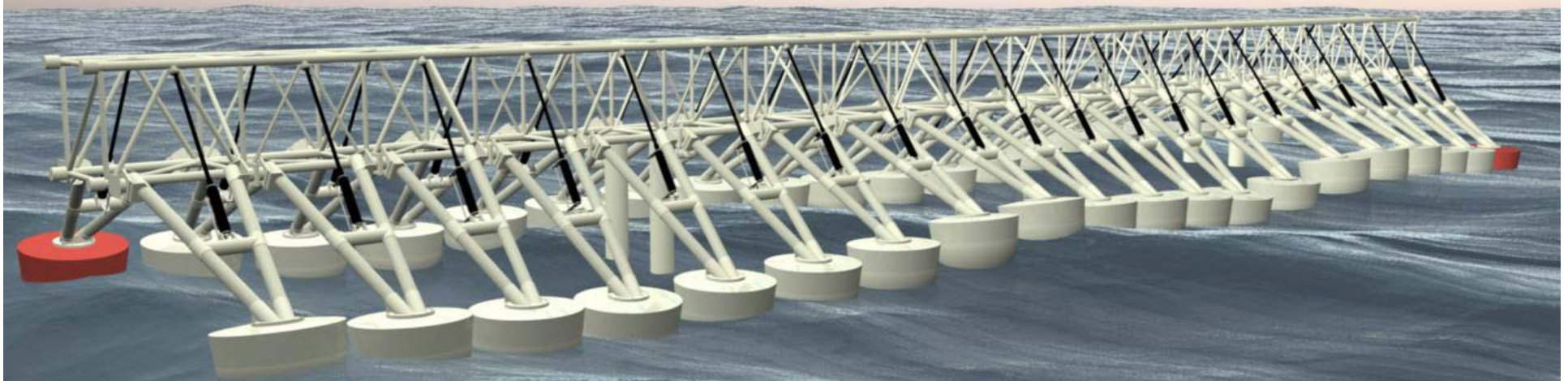

Numerical modelling

Scale 1:40 testing at AAU

Scale 1:10 testing in Nissum Bredning

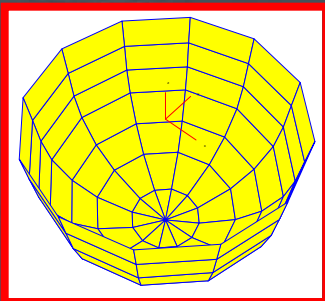

Bremerhaven, 25 October 2006

# Wave Star characteristics

- It is based solely on standard components, standard offshore and **wind turbine technology.**
- The Wave Star machine is placed on a pile structure on the seabed – in 7 to 30 meters of water
- It can be shut down if waves exceed 8 metres – storm protection mode

# Normal operation

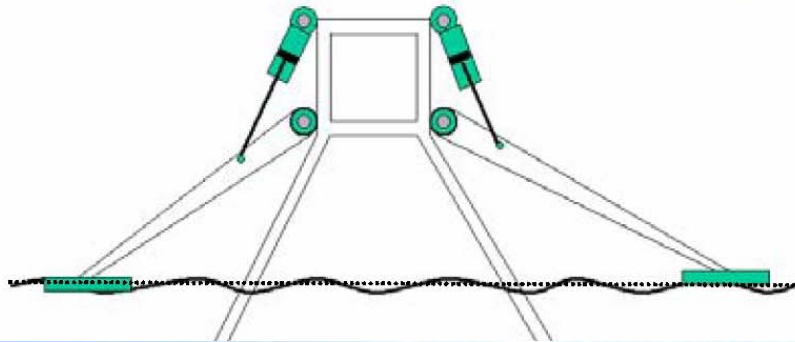

# storm protection

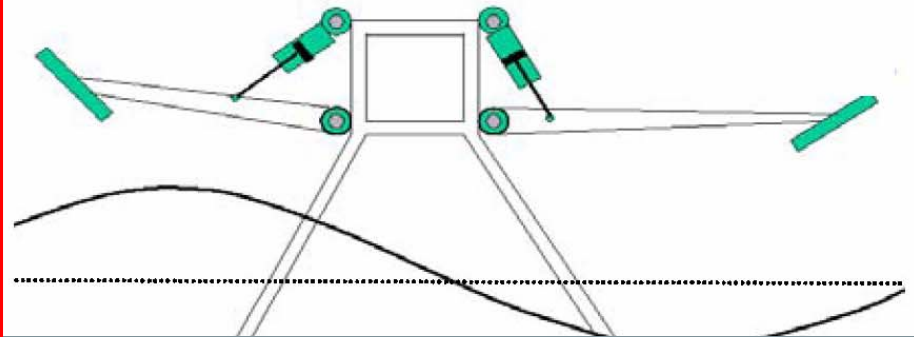

# Numerical modelling

*Boundary Element Method (BEM) & linear potential theory*

- Float shape, draft & diameter

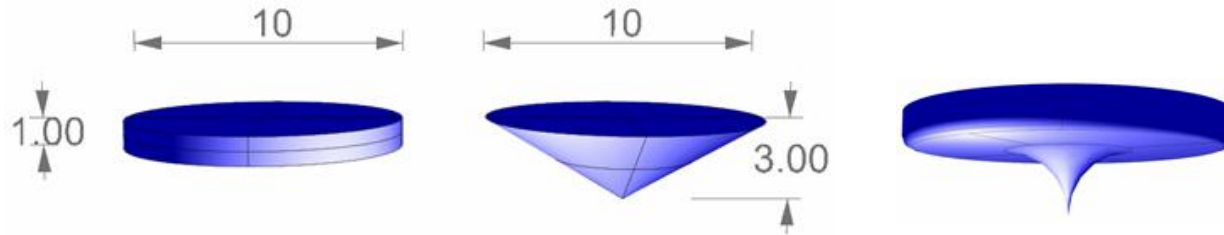

- Float arrangement (gaps in x and y direction)

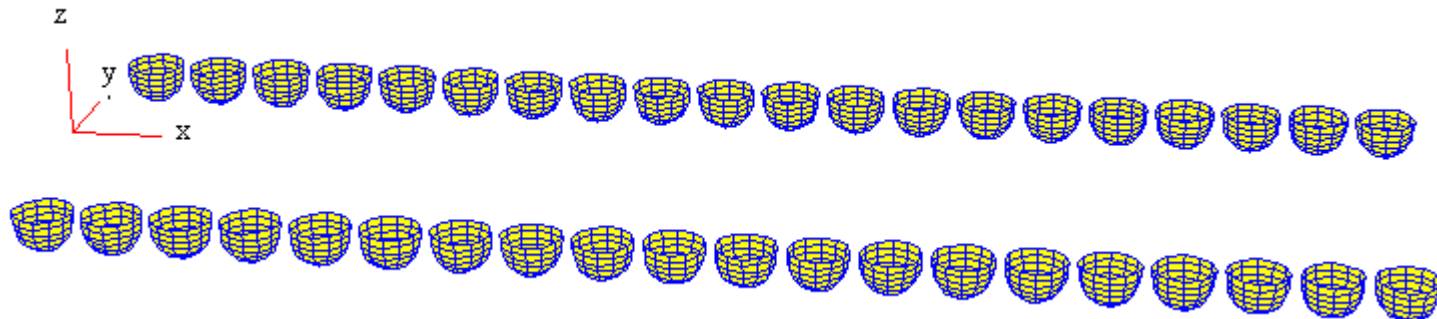

# Numerical modelling

The image displays the WaveStarSim 0.5 (beta version) software interface, which is used for numerical modelling of wave energy converters. The interface is divided into several windows:

- Inputs:** Contains tabs for Wave, Geometry, Hydraulics, Power take off, and Constants. The "Global layout of device" section includes input fields for "Distance center-center x (m)" (1.2), "Distance center-center y (m)" (7), and "Number of floats" (40), along with a "Show/redraw" button. The "Single absorber layout" section includes a dropdown menu for "Testflyder10" and a "Float type scale" input (1: 10). The "Geometry" section lists parameters: "Mass of float (kg)", "C: Length of arm (m)", "D: Hydraulic cylinder point of attack (m)", "E: Lattice height (m)", and "BH: Bearing height above sea bed (m)".
- Global layout of device:** Shows a top-down view of a device consisting of two parallel rows of 20 red circular floats each. A blue arrow labeled "Wave input" points towards the floats from the left.
- Geometry of float and arm at neutral position:** A detailed diagram of a float and its arm. The float is a semi-circular shape partially submerged in water. The arm is a long, thin structure attached to the float. The diagram shows the "UP" and "DOWN" buttons for "Float position" and "UP" and "DOWN" buttons for "Water level". The "Draft" is 0.3176 m and the "Submerged volume" is 0.1249 m<sup>3</sup>. There are "Reset", "Add definitions", and "Figure plotting options" buttons.
- Waves in one point:** Contains tabs for Wave, Geometry, Hydraulics, Power take off, and Constants. It includes input fields for "Water depth (m)" (2), "Wave direction (deg)" (-30), "Wave input point" (x = 0, y = 0), and a "Jonswap spectrum" dropdown. Below these are fields for "Significant wave height (m)" (0.25), "Peak period (s)" (2.5), "Peak enhancement factor" (3.3), "Number of frequencies" (Automatic), and "Length of time series (s)" (Automatic). At the bottom, there is a "Sample frequency (Hz)" field set to Automatic.

# Scale 1:40 testing

At Aalborg University, Department of Civil Engineering

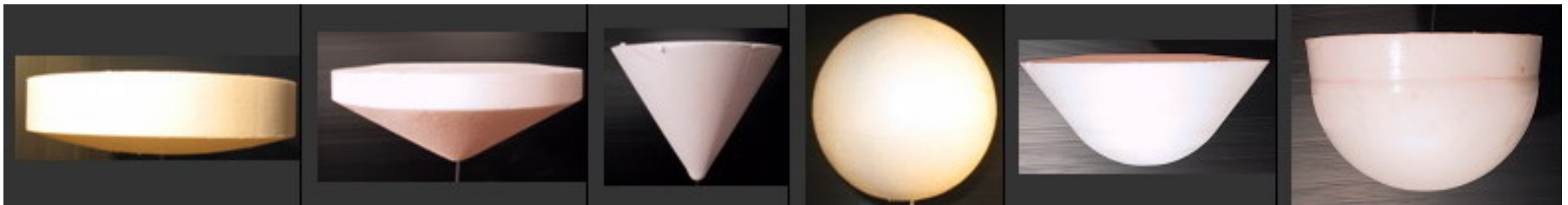
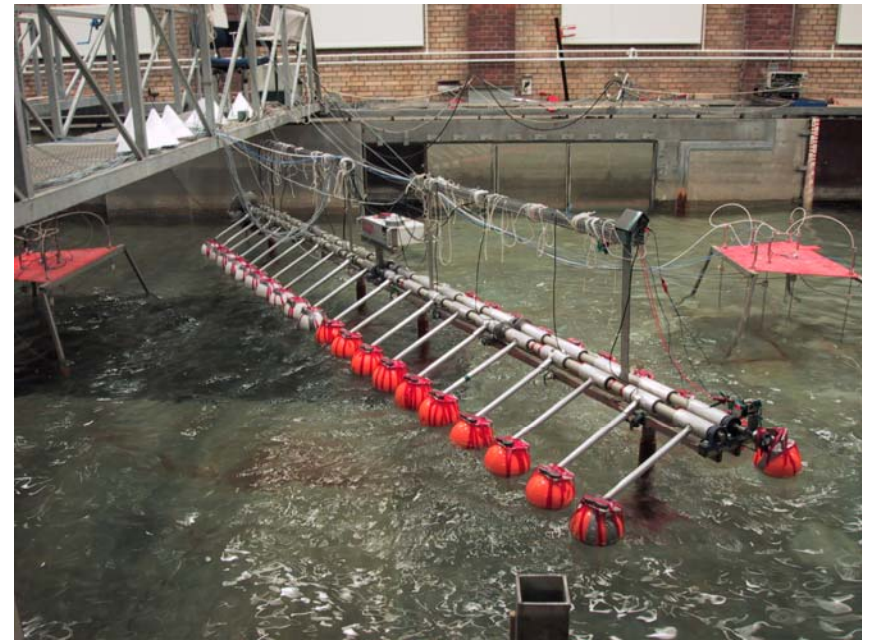

Influence of: Waves ( $H_s$ ,  $T_p$ , direction), water level, float type (diameter, shape & weight), float numbers (1, 10, 20, 40) and gap widths

# Scale 1:40 testing

At Aalborg University, Department of Civil Engineering

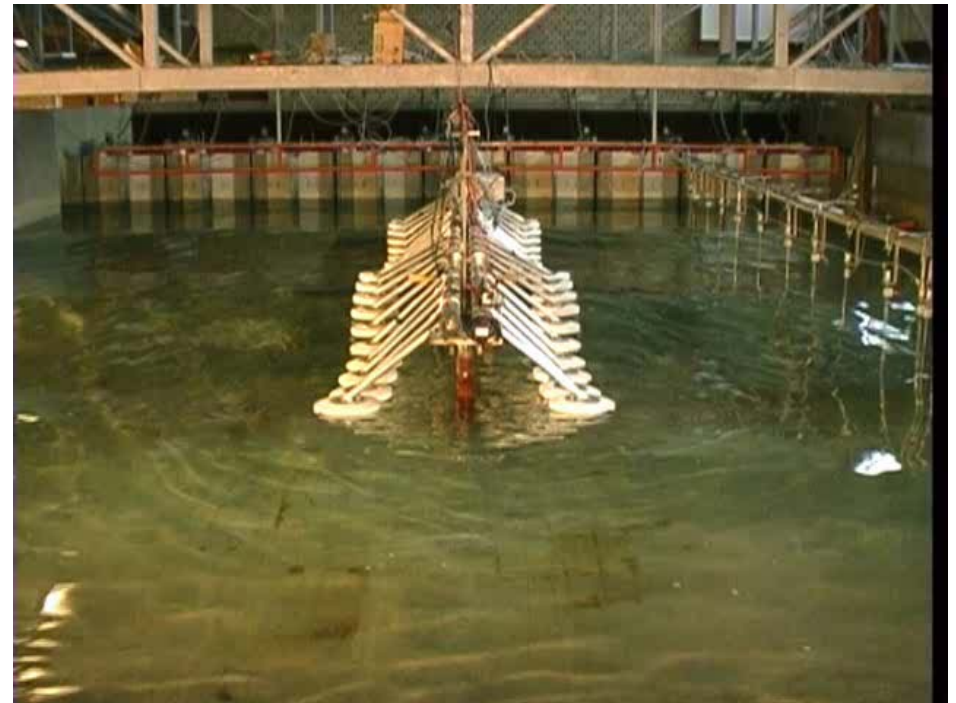

# Scale 1:10 *real sea* tests in Nissum Bredning



Left: Main structure before it was transported to sea



Right: Arm before installation

# Normal operation



# storm protection



# Goals for the near future development

## 2004-2005

- All wave tank testing on scale model 1:40 has been done, based on North Sea wave data

## 2006-2008

- A true scale model 1:10 test machine, based on hydraulics, is being tested in the sea at Nissum Bredning

## 2007

- A scale 1:2 production machine with two floats will be installed by the harbour at Hanstholm (Roshage pier) and tested in the sea.

## 2008/9 →

- A scale 1:2 production machine of 500 kW with 40 floats will be built and installed in the North Sea in 10 m of water depth.

## Target power production for machine with 40 floats

Scale	Depth (m)	Length (m)	Float dia. (m)	$H_s$ (m)	Power
1:10	2	24	1	0.5	1800 W
1:2	10	120	5	2.5	500 kW
1:1	20	240	10	5.0	6 MW
1½:1	30	360	15	7.5	24 MW



\* Leaflets

\* [www.wavestarenergy.com](http://www.wavestarenergy.com)

**Morten Kramer**  
Assistant Professor. M.Sc., Ph.D.

Aalborg University  
Department of Civil Engineering  
Sohngaardsholmsvej 57  
DK-9000 Aalborg

Room C-226. E-mail: [mkr@civil.aau.dk](mailto:mkr@civil.aau.dk)